

**Valvola overcenter doppia, montaggio a flangia**  
**Dual overcenter valve, gasket mounted**

Rev.02-2010/05

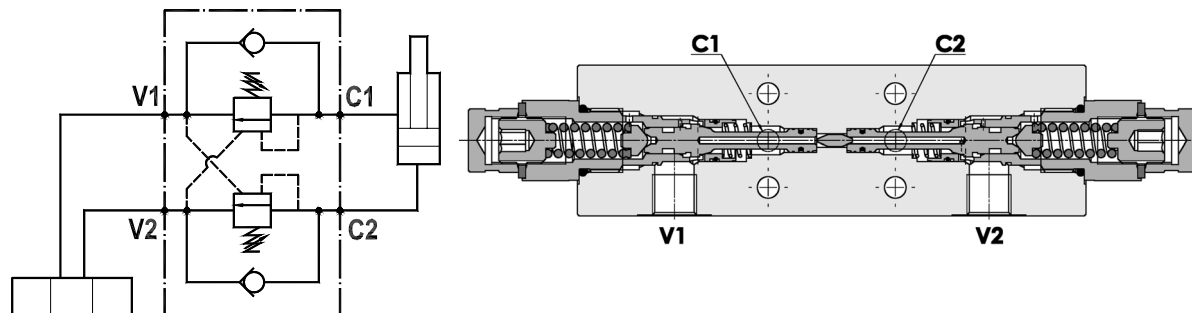

**SPECIFICHE TECNICHE**

**Materiali:** corpo in acciaio zincato. I componenti interni sono in acciaio trattato termicamente.

**Portata max.:** 35 l/min

**Taratura max.:** 350 bar

**Rapporto di pilotaggio:** 1 : 4 (a richiesta 1 : 8, 1 : 11)

**Regolazione pressione:** mediante vite

**Campo di regolazione pressione:** vedere pag.02

**Peso:** 2,000 Kg

**TECHNICAL SPECIFICATIONS**

**Materials:** body is in steel zinc plated. Internal parts are in hardened steel.

**Rated flow:** up to 35 l/min

**Max. setting:** 350 bar

**Pilot ratio:** 1 : 4 (1 : 8 and 1 : 11 on request)

**Adjustment means:** leakproof screw.

**Adjustable pressure range:** see page 02

**Weight:** 2,000 Kg

**DIAGRAMMA PERDITE DI CARICO - PRESSURE DROP CURVES**

Viscosità olio 24 mm<sup>2</sup>/sec. (3,5 °E)  
 Temperatura 50 °C

Oil viscosity 24 mm<sup>2</sup>/sec. (3,5 °E)  
 Temperature 50 °C

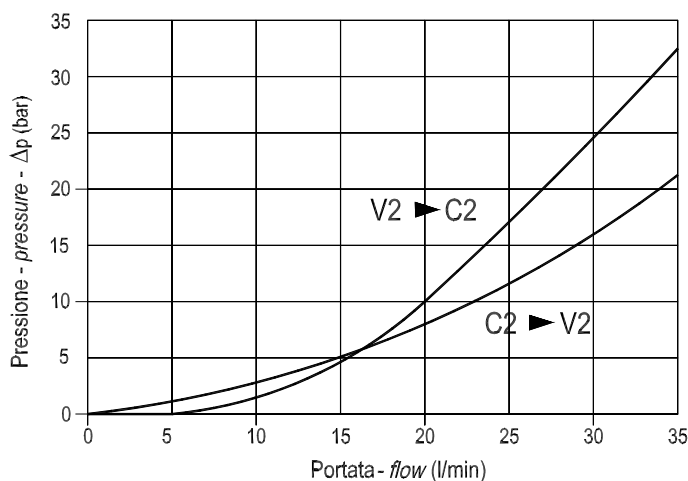

**Valvola overcenter doppia, montaggio a flangia**  
**Dual overcenter valve, gasket mounted**

Rev.02-2010/05

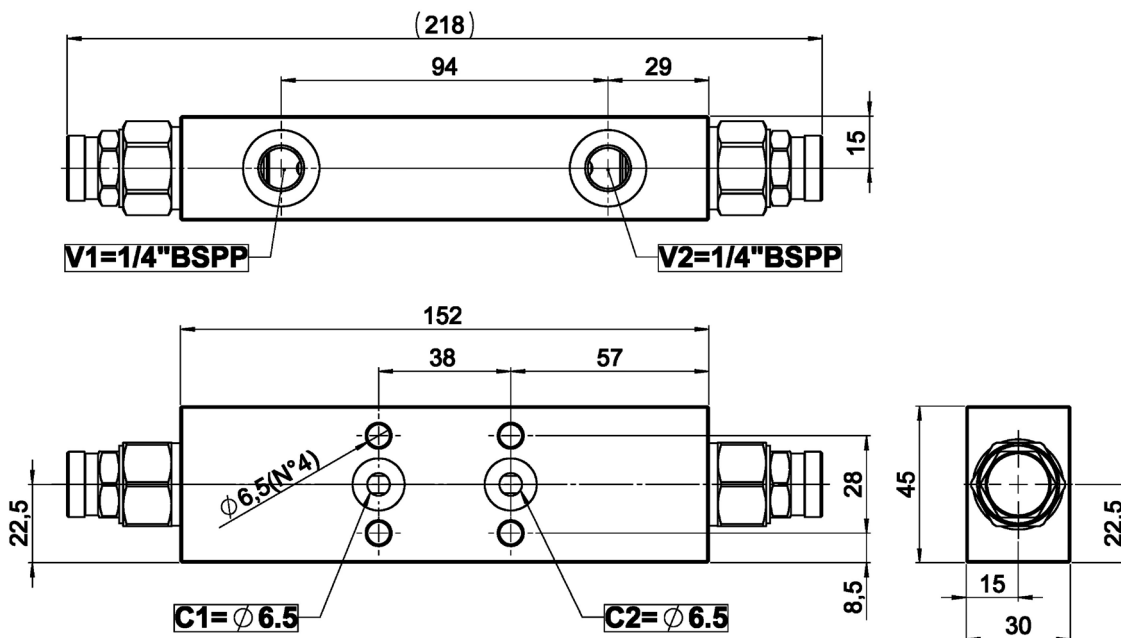

MOLLE - SPRINGS				*
Codice Code	Rapp. pil. Pilot ratio	Campo taratura min.-max. bar Adjustable pressure range bar	Increment. press. bar/giro vite Pressure increase bar/turn	Taratura standard bar Standard setting bar
20	1 : 4	60 - 250	65	170
35	1 : 4	100 - 350	110	280
	1 : 8	80 - 350	140	
	1 : 11	80 - 350	160	

**ESEMPIO DI ORDINAZIONE - ORDERING CODE EXAMPLE**

**F P O** **3 5** **D** **1 / 4** **2 F** **3 5** **B**

\* "20" / "35":

Campi di taratura pressione - Adjustable pressure range

Rapporto di pilotaggio - Pilot ratio

Omettere se std - Omit if std \*

B = 1 : 8, C = 1 : 11